

# PILOT ACTION REPORT

# PILOT 8

---

Rzeszowski pilot action report:

D.T3.1.17

---

---

PP10

Rzeszow Regional Development Agency

11 2020

---



## **1. Summary description of the pilot action explaining its experimental nature and demonstration character**

At the start of the Hicaps project we had detailed planning phase that included analysis, studies and detailed design of renovation. Preparation phase included landscape design, planning planting specific plants, flowers, trees and small infrastructure works that were needed.

After that, we started reconstruction works.

Works done through the Hicaps project

- 5 signposts and 2 tablets providing better information to the visitors, described stories from the past, wildlife, photos
- restoration of the garden concerning vegetation, paths, antique fountain, irrigation.

Thanks to revitalization works, not only the historical layout and species composition of plants restored, but additionally, accessibility for people with physical disabilities increased through new surfaces. Properly prepared information boards allowed blind and visually impaired people to learn about the history of the foundation and the characteristic elements of this garden interior. In addition, the venture gained educational and natural value – increased the awareness of shaping historic gardens and parks throughout history. In this particular case, society will learn the elements of Polish typical time design, i.e. of the 20th century. It should be remembered that garden art is part of the historical consciousness of humanity. The combination of a revitalized Italian garden with architecture completed work of art and became an element of cultural and natural heritage.

The revitalization of the Italian garden took place on the basis of existing and available authentic historical documentation, which further emphasizes its unique character and take the viewer to such a wonderful thirties of the twentieth century.

## **2. Describe stakeholder engagement and involvement during the whole process**

- ❖ Local public authority: 5 persons, 3 instytution: Representative of Castle in Łańcut; The arboretum in Bolestraszyce, Urząd Gminy Kuryłówka
- ❖ Regional public authority: 10 persons , 5 instytutions: Powiat Center for Culture and Tourism in Wiśniowa, Provincial Hospital in Rzeszów, General Directorate for National Roads and Motorways, Marshal's Office of the Podkarpackie Voivodeship. Rzeszow Regional Developmet Agency,

- ❖ National public authority: 2 persons, 1 institutions: Director of the Deputy's Office - Member of the Polish Parliament
- ❖ Sectoral agency: 1 Gliwice Tourist Agency
- ❖ Interest groups including NGOs: 8 NGOs and association, 9 persons:
  - Youth Assistance Foundation "GROWTH" - 2
  - Fundation Pro Arte et Historia - 1
  - Rzeszów Social Economy Support Center - 1
  - SWEP - 1
  - Victoria Association - 1
  - Dobry Dom Association - 1
  - Vocational Development and Training Centre in Nowa Sarzyna – 1
  - PZOZAZ Rzeszów 1
- ❖ General public: 42 visitors who completed the survey, 4 persons from media
- ❖ Higher education and research: 5 persons, 3 Univers.
  - Cardinal Stefan Wyszyński University in Warsaw 1,
  - Rzeszow University 3,
  - Pedagogical University of Cracow 1
- ❖ Business support organization : 6 companies, 6 persons.
  - Symii LLC,
  - e-Space,
  - Danmar Computers,
  - Eurobud,
  - Opteam,
  - Seth.
- ❖ Educational/training centre schools: 18 Students of primary schools.

During the workshop, the experts, thanks to the HICAPS project, tried to awake the awareness of the importance of nature, to teach how to care for nature through the protection of green areas, introduce the importance of historical parks and treat it as cultural heritage.

### **3. Investment location (NUTS 3 region(s), adress, postal code, city, country)**

Country (NUTS 0) – Poland

Region (NUTS 2) PL32, Podkarpackie

Sub-region (NUTS 3) PL325, Rzeszowski

The historic park of the Lubomirski and Potocki families is located in the center of Łańcut in the Podkarpackie Voivodeship. The whole complex is situated on a small hill, its area is 36 ha and it is divided into an internal garden (in the immediate vicinity of the Castle, framed by a moat) and an external park.

#### 4. Description of the investment, including technical characteristics

A. Purchase of flower beds modeled on those from the beginning of the 20th century;

## H1050

## konstrukcja stojąca



**informacje techniczne**  
(mm)



widok z boku

**Jakości i bezpieczeństwa nie da się skopiować.** Tylko oryginalne produkty sygnowane marką Terra® gwarantują najwyższą jakość, bezpieczeństwo oraz staranność wykonania.

**produkt opatentowany**  
P 379058

zastroszony wód przemysłowy  
Wp 8324-25

■ wyprodukowane w Polsce gwarancja 24 miesiące

ilość poziomów	5	waga przed obsadzeniem	45 kg
kubatura	397 litrów	waga po obsadzeniu	275 - 490 kg
wysokość całkowita	1160 mm	szacunkowa ilość sadzonek	60 - 72 sztuk
średnica podstawy	1050 mm	gwarancja	24 miesiące

waga uzależniona od rodzaju i wilgotności gleby

Kaskadowe Konstrukcje Kwiatnikowe firmy Terra® objęte są 2-letnim programem gwarancyjnym "DOOR TO DOOR". W rzeczywistości jest to rozbudowany system wsparcia i pomocy technicznej, a także wyjątkowo sprawnie działający serwis gwarancyjny. W momencie wykrycia usterek w naszych produktach, serwisanci dokonują jego naprawy w wyznaczonym przez Państwa miejscu lub wymieniają produkt na nowy.

**kolory**



**System DUPLEX (1-4)** Połączenie powłoki cynkowej oraz warstwy poliestrowej strukturalnej farby proszkowej gwarantuje wyjątkowo odporną powłokę ochronną, której trwałość można określić jako podwójny łączny sumy obu tych powłok.

**Stal nierdzewna (5)**

**metoda produkcji**

pierścienie cięte laserowo

pierścienie spawane w technologii MAG/TIG

wszystkie elementy cynkowane ognioowo

pierścienie malowane proszkowo po zewnętrznej stronie (system DUPLEX)

# H1200

karta techniczna

## konstrukcja stojąca



transport  
(mm)

1 widok z boku

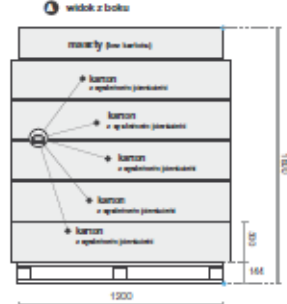

2 widok z przodu

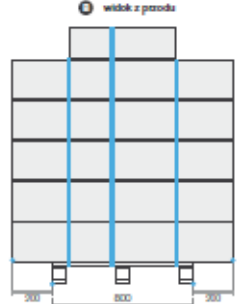



3 ZESTAWY W KARTONIE

4 ZESTAWÓW NA PALECIE CIĘTO

zawartość zestawu	Misa dolna z nogami	1 szt.	Paleta	4 szt.
	Pierścienie	4 szt.	Płaskownik zabezpieczający	2 szt.
	Sznur 10x50	14 szt.	Utrzymki	15 m
	Mazur (profil 60x50 mm)	1 szt.	Klej do szorstki	2 szt.

akcesoria dodatkowe

 system wykorzystawczy



 moduł transportowy



 system nawadniania TerraClick T7





B. Laying the rebate and leveling and sowing grass;







C. 2 educational and information boards;











**Rewitalizacja ogrodu włoskiego w zabytkowym parku w Łańcucie**

**Tytuł projektu - "HICAPS - Historical Castle Parks"**

Cel projektu - Projekt HICAPS ma na celu wzmocnienie potencjału sektora publicznego i prywatnego, poprawę zarządzania historycznymi parkami i zwiększenie świadomości na temat parków jako dziedzictwa kulturowego.

Zródło współfinansowania - "Projekt współfinansowany ze środków Europejskiego Funduszu Rozwoju Regionalnego w ramach programu INTERREG CENTRAL EUROPE".

[www.interreg-central.eu/hicaps](http://www.interreg-central.eu/hicaps)

Ogród włoski został założony na pocz. XX wieku przy elewacji wschodniej Zamku na polecenie Elżbiety i Romana Potockich. Projekt wykonał, pochodzący z Genui, włoski architekt Albert Pio. Główną część ogrodu stanowi wgłębnik w formie rzymskiego hipodromu z regularnie rozmieszczonymi rabatami kwiatowymi i bogatym wystrojem rzeźbiarskim. Centralnym punktem tej części jest rzeźba Bacchusa na panterze. Od strony zachodniej widzimy drewnianą żardinierę opartą na marmurowych podstawach, a w części wschodniej ogrodu dominuje rzeźba Orta napoleońskiego. W wyniku przeprowadzonych prac rewitalizacyjnych został przywrócony historyczny wygląd z lat 30-tych XX wieku wraz z roślinnością i wyposażeniem. Obsada ogrodu włoskiego wykonywana jest dwukrotnie w ciągu roku - w maju i październiku. W tym celu wykorzystywane są, podobnie jak w przeszłości, rośliny jednoroczne i dwuletnie (np. begonia, szalwia, bratek).



Brailła

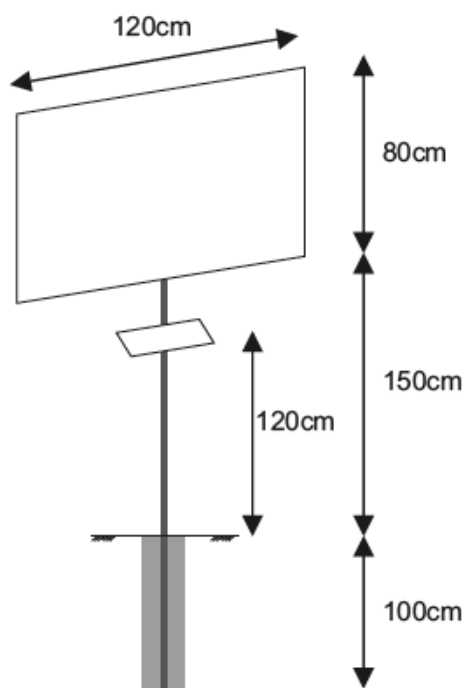

D. 5 direction indicators





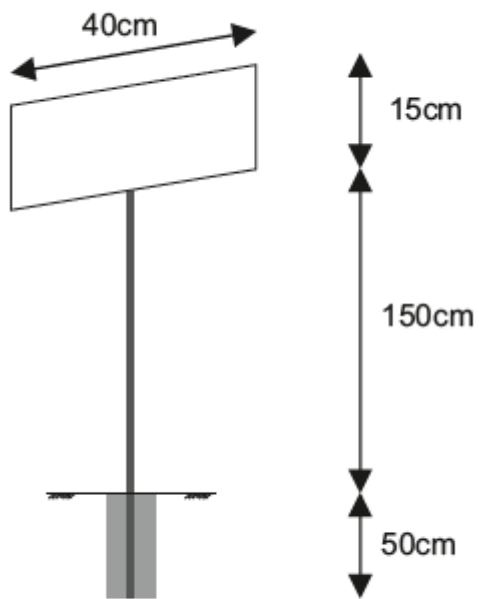





E. Planting with flowers;



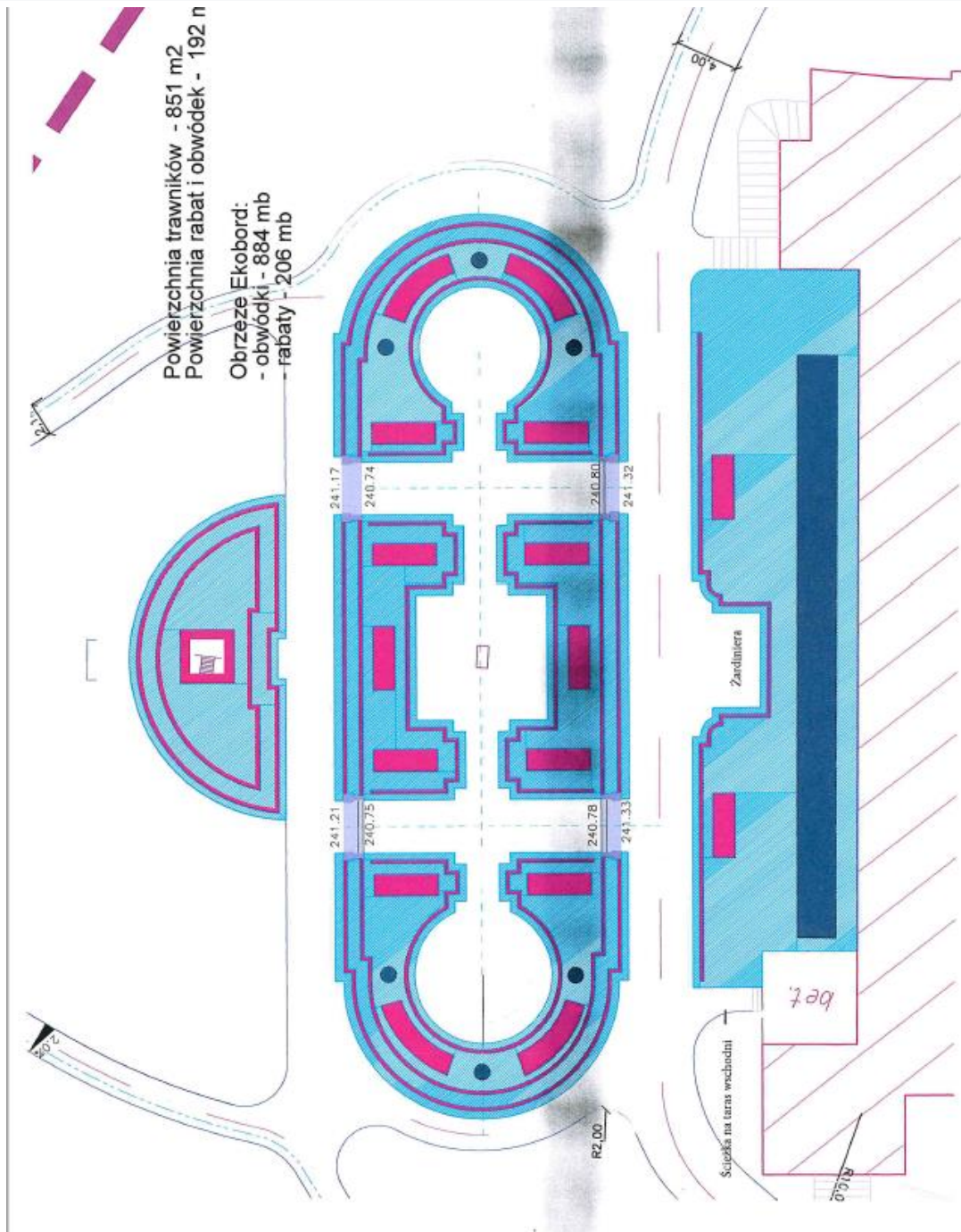





F. The irrigation system has been partially changed and repaired.

**5. Which horizontal principles did you take in consideration during preparation and implementation process (equal opportunities, non-discrimination, economic aspect, barrier –free accessibility)**

For activities in HICAPS pilot project, special long term agreement with owner of the Castle of Łańcut was needed. During revitalization and construction works, special attention was paid to protect all trees, plants in park. When choosing materials for equipment in Park, we avoided materials with negative impact on environment.

1. All project activities have been carried out in accordance with national and EU legislation.
2. Our investment did not interfere negatively with the environment - it involved minor changes in the park's landscape. That project will have positive affect on sustainable development of the program area and participating regions. Specially on further development on natural and cultural resources: new business opportunities in tourism sector.
3. Results of project - available for all in cultural landscape.

**6. Duration and process of investment implementation**

Works after conducting public procurement procedures, weather permitting, Covid-19 situation: in the period of December 2019 - May 2020.

**7. If applicable, compliance with relevant regulatory requirements**

All project activities have been carried out in accordance with national and EU legislation.

**8. Major milestones of investment**

The work was divided into parts. Some were part of other orders. Many dates were changed by Covid-19.

Dates of done works:

- Purchasing of flower beds modeled on those from the beginning of the 20th century - XII 2019
- Laying the rebate and leveling and sowing grass V 2020
- installation of 2 educational and information boards and 5 direction indicators V 2020
- Planting with flowers V 2020
- The irrigation system has been partially changed and repaired V 2020

## **9. Investment costs (BL5, BL6: including break-down of main costs items) in EUR**

According to the project budget:

BL5 Equipment expenditure = 3 978,11 Eur

BL6 Infrastructure and works expenditure = 9 580,94 Eur

Total = 13 559,05 Euro

## **10. Ownership and durability of the investment (e.g. maintenances, financing)**

### THE OWNERSHIP OF THE SITE

The Łańcut Castle Museum is a cultural institution with legal personality run jointly by the Minister of Culture and National Heritage and the Podkarpackie Voivodeship, entered on January 1, 2006 under item 67/2006 into the Register of Cultural Institutions kept by the Minister of Culture and National Heritage.

RRDA and Muzeum-Park in Łańcut, on the basis of a long-term contract, have decided to:

The durability of the project will be maintained for a minimum of 5 years from the end of the project. However, the durability of the project will certainly remain preserved for many years to come as the completed tasks are to be used in a very long-term perspective.

The durability of the project will certainly remain preserved for many years to come as the completed tasks are to be used in a very long-term perspective.

Sustainability will be continued and project results will be used after the end of the funding period.

Project partners and other entities can follow our idea as the preservation of tradition and history takes place for present and future generations.

Sustainability will be guaranteed by the immediate implementation of the new knowledge acquired through HICAPS, to fill the missing gaps and produce new services, usable for a long time. The plan will be used in revitalization concepts and pilots, so it will be used by all the stakeholders involved in the HICAPS historical parks.

Transferability will be ensured through dissemination and already established partners network to transfer the outputs to other regions and cities in Poland and in Central Europe.

### **11. Expected impact and benefits of the pilot action for the concerned territory and target groups**

Expected impact of the project is to encourage an interest in history and cultural heritage in public especially tourists, young people and children. During the 3rd period of this project (IX 2018), we organized a workshop for school children and presented them the HICAPS project. They learned about the importance of cultural and historical heritage, the castle and the castle park. They were very pleased with the presented information. We hope that they will remain interested in and visit the park more often in the future.

There are also a school, high school nearby the castle park. Kids are going for a walk every day, so now they can go in the renovated park for a walk on the pathway. They can learn something new, about history, castle, plants, discover Braille that is not in everyday use and of course, they can learn about the HICAPS project. All listed information is printed on information tables.

We know that children are curious, they learn quickly and habits they get, remain.

Through planning this project, particular attention was paid to provide access for people with disabilities in moving.

### **12. Lessons learned from the implementation of the pilot action**

Thanks to international cooperation we gained:

- learning new organizational and technical solutions;
- getting to know better partner's culture and the way how they protect cultural and historical heritage
- approaching problems, solutions and methods from a different perspective;
- the opportunity to develop a truly European way of thinking;
- including professional staff in international exchange;
- transfer of good practices between partners;
- increasing awareness and knowledge;

- the possibility of using ready-made solutions and "good practices" developed by transnational partners;
- experience in building and managing partnerships.

We had excellent cooperation with all partners and all possible support of Lead partner Municipality of Velenje.

### **13. Transferability to other territories and stakeholders**

The park is part of the landscape of the region. It is a showcase of the region that attracts thousands of tourists from the country and abroad. Investments in the park, which were done through this project was in line with the level of the legal possibilities and at the same time harmonized and discussed with the relevant bodies.

The park will need to be keep sustainable in terms of regular gardening, in the Park work many qualified people, there are no plans to additional employment, or introduction of fees and tickets for visiting the park. The park is opened for public and visited by local population, tourists, school kids, families with kids, senior citizens, people with reduced mobility, etc.

The park is ready to share tips on implemented activities with other entities.

The park carries out many promotional and dissemination activities, incl. annual music festival

- The Music Festival in Łańcut has been taking place since 1961, presenting performances by leading performers from the world of classical music.

### **14. Added value of transnational cooperation**

Thanks to international cooperation we gained:

- learning new organizational and technical solutions;
- approaching problems, solutions and methods from a different perspective;
- the opportunity to develop a truly European way of thinking;
- including professional staff in international exchange;
- transfer of good practices between partners;
- increasing awareness and knowledge;
- the possibility of using ready-made solutions and "good practices" developed by transnational partners;
- experience in building and managing partnerships.

### **15. References to relevant deliverables and web links**

Deliverable D.T1.1.3 Good practices analysis report (GPAR)

Deliverable D.T3.1.1 Revitalization concept

Deliverable D.T3.1.16 Detailed technical plan

Deliverable D.T3.1.17 Rzeszow pilot action report

### **Some news:**

A. Gazeta Wyborcza

<https://rzeszow.wyborcza.pl/rzeszow/7,34962,25986900,pekny-ogrod-wloski-wrocil-do-wygladu-sprzed-blisko-stu-lat.html>

B. Nowiny

<https://nowiny24.pl/ogrod-wloski-w-muzeum-zamku-w-lancucie-juz-po-rewitalizacji-zdjecia/ar/c7-14998485>

C. Radio Rzeszow

<https://www.radio.rzeszow.pl/#ajx/wiadomosci/32101/lancut>

D. Łańcut Gada

<http://www.lancut.gada.pl/aktualnosc,5149,0,0,0,Zakonczenie-prac-rewitalizacyjnych-w-Ogrodzie-Wloskim.html>

E. Puls Biznesu

<http://www.pulspodkarpacia.pl/lancut-przywrocono-przedwojenny-wyglad-ogrodow-na-zamku-lancuckim/>

F. Carpatia Biznes

<https://www.carpatiabiznes.pl/muzeum-zamku-w-lancucie-ogrod-wloski-znow-wyglada-jak-w-latach-swietnosci-rezydencji/>

### **16. Pictures and some images**













